

**DETAIL LIMITS**  
STA. 2180+07.00 - STA. 2187+97.74

**DETAIL LIMITS**  
STA. 2179+50.00 - STA. 2183+10.00

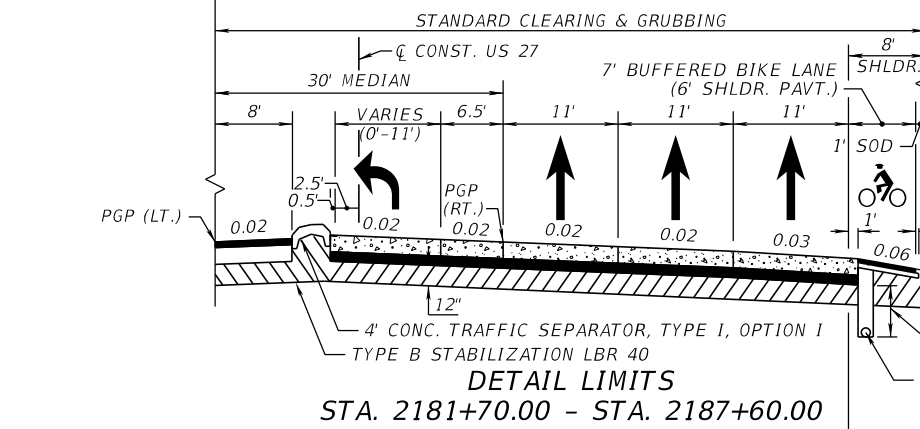

**DETAIL LIMITS**  
STA. 2181+70.00 - STA. 2187+60.00

**MILLING**  
MILL EXISTING ASPHALT PAVEMENT FOR DEPTH (2.25")

**RESURFACING**  
TYPE SP STRUCTURAL COURSE (TRAFFIC D) (1.5") (PG 76-22)  
AND FRICTION COURSE FC-5 (0.75") (PG 76-22)

**NEW CONSTRUCTION / WIDENING**  
OPTIONAL BASE GROUP 12 WITH  
TYPE SP STRUCTURAL COURSE (TRAFFIC D) (4")  
TYPE SP STRUCTURAL COURSE (TRAFFIC D) (2") (PG 76-22)  
AND FRICTION COURSE FC-5 (0.75") (PG 76-22)

**TYPICAL SECTION**  
SR 25 (US 27) (SUBURBAN)  
STA. 2175+40.00 - STA. 2191+15.00

**NEW CONSTRUCTION (RIGID)**  
OPTIONAL BASE GROUP 1 (TYPE B-12.5 ONLY) WITH  
PLAIN CEMENT CONCRETE PAVEMENT (9")

**SHOULDER PAVEMENT**  
OPTIONAL BASE GROUP 6 WITH  
TYPE SP STRUCTURAL COURSE (TRAFFIC D) (2.5") (PG 76-22)  
AND FRICTION COURSE FC-5 (0.75") (PG 76-22)

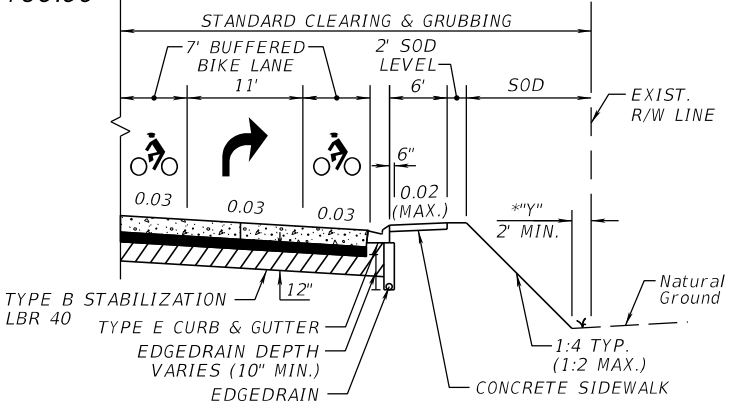

**DETAIL LIMITS**  
STA. 2190+85.00 - STA. 2191+15.00

\*\*"Y" THE AREA DISTURBED BY CONSTRUCTION VARIES.

(UNDER PAVED SHOULDERS) AT THE CONTRACTOR'S OPTION, THIS AREA MAY BE CONSTRUCTED OF BASE MATERIAL AT NO ADDITIONAL COMPENSATION.

ACTUAL WIDTH OF BASE WIDENING MAY VARY DUE TO ACTUAL EXISTING PAVEMENT WIDTH. CONTRACTOR MAY ELECT TO PLACE UNIFORM WIDTH BASE WIDENING STRIP AT NO ADDITIONAL COST TO THE DEPARTMENT.

**TRAFFIC DATA (S. OF SR 60)**  
CURRENT YEAR = 2016 AADT = 27,000  
ESTIMATED OPENING YEAR = 2020 AADT = 32,000  
ESTIMATED DESIGN YEAR = 2040 AADT = 57,600  
K = 9.50% D = 56.0% T = 18.0% (24 HOUR)  
DESIGN HOUR T = 9.00%  
DESIGN SPEED = 50 MPH

REVISIONS				Kisinger Campo & Associates Corp. 201 N. Franklin Street, Suite 400 Tampa, Florida 33602 Florida Certificate of Authorization No. 02317 Engineer of Record: Todd M. Gardina, P.E. P.E. No.: 66373	STATE OF FLORIDA DEPARTMENT OF TRANSPORTATION			SHEET NO.  17
DATE	DESCRIPTION	DATE	DESCRIPTION		ROAD NO.	COUNTY	FINANCIAL PROJECT ID	
					SR 25	POLK	419243-4-52-01	

**TYPICAL SECTION (1)**

THE OFFICIAL RECORD OF THIS SHEET IS THE ELECTRONIC FILE DIGITALLY SIGNED AND SEALED UNDER RULE 61G15-23.004, F.A.C.